



**BRANO a.s., 747 41 Hradec nad Moravicí
the Czech Republic**

tel.: +420/ 553 632 303

<http://www.brano-zz.cz>; <http://www.brano.eu>;

zz-info@brano.eu; info@brano.eu

OPERATION MANUAL SECURITY PRINCIPLES, OPERATION AND MAINTENANCE FOR

ROPE WINCH

LN type

Load capacity 0,5t and 1t

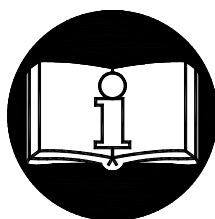
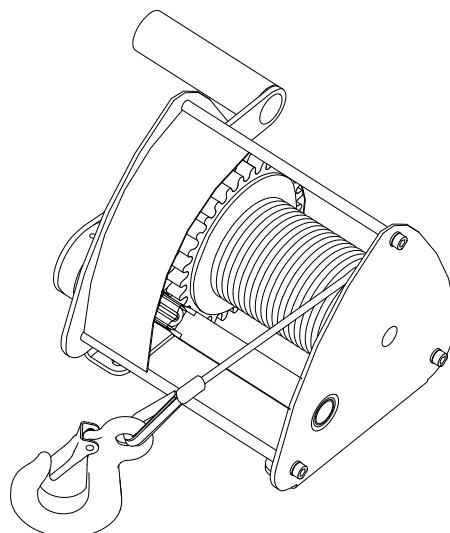

Peruse the Operation Manual prior to use of this product. It comprehends substantial security instructions and instructions for use, installation and maintenance of the product. Ensure the Operation Manual is available for all responsible persons.

Keep for next usage!

CONTENT

1 SECURITY DEFINITION	3
2 DEVICE APPLICATION	3
3 SECURITY PRINCIPLES	4
3.1 SECURITY PRINCIPLES OVERVIEW	4
3.2 SECURITY PRINCIPLES	4
3.2.1 Prior to use	4
3.2.2 When in use	5
3.2.3 After use	5
3.2.4 Risk analysis	5
3.2.5 Maintenance	5
4 ACCESSORIES, PACKING, STORAGE AND HANDLING	6
4.1 ACCESSORIES	6
4.2 PACKING	6
4.3 STORAGE	6
4.4 HANDLING	6
5 MAIN SPECIFICATIONS	7
5.1 MECHANICAL CLASSIFICATION	7
5.2 MATERIAL AND FINISH	8
5.3 DATA ON THE PRODUCT	9
6 WINCH INSTALLATION	9
6.1 CHECK BEFORE INSTALLATION	9
6.1.1 Load bearing structure	9
6.1.2 Check of rope	9
6.2 WINCH ATTACHMENT	10
6.3 WINCH POSITION WHEN PULLING AND LIFTING	10
6.4 INSTRUCTIONS FOR WINCH OPERATING STAFF	11
6.4.1 Stretching and slacking of rope	11
6.5 TEST PRIOR TO USE	12
7 OPERATION	12
7.1 WINCH APPLICATION	12
7.2 LIFTING AND LOWERING	13
7.3 SAFETY WORK ENVIRONMENT	14
8 WINCH INSPECTION	14
8.1 INSPECTION	14
8.2 INSPECTION PROCEDURE	16
9 TROUBLE-SHOOTING	18
10 GREASING	19
10.1 GENERAL	19
10.2 GEARS	19
10.3 ROPE	19
11 MAINTENANCE	19
11.1 SECURITY PRINCIPLES	19
11.2 ROPE REPLACEMENT	20
11.3 GENERAL INSTRUCTIONS	20
11.4 BRAKE ASSEMBLY AND ADJUSTING	21
11.5 CHECK UP	21
11.6 REPAIR	22
11.7 TEST	22
12 PUTTING OUT OF OPERATION – DISPOSAL	22
13 RELATED DOCUMENTATION	22
14 FINAL REQUIREMENTS OF THE PRODUCER TO THE CUSTOMER	22

1 SECURITY DEFINITION

! HAZARD **Hazard:** it adverts to an imminent hazardous situation, which will inflict a death or serious injury, if the operation personnel do not avoid it.

! WARNING **Warning:** it adverts to a possible hazardous situation, which could inflict a death or serious injury, if the operation personnel do not avoid it.

! NOTICE **Notice:** it adverts to a possible hazardous situation, which could inflict any minor or slight injury, if the operation personnel do not avoid it. The notice can warn against hazardous practices as well.

Load capacity (Q): is the maximum permitted weight (working load limit), by which the winch can be loaded when handling with a load on conditions specified in this Operation Manual.

2 DEVICE APPLICATION

2.1 The LN type rope winch with load capacity 0,5t and 1t (hereinafter referred to as the product) is designed to pulling, lifting and lowering of free loads on conditions specified by the Operation Manual.

2.2 The product has been designed in compliance with the requirements stipulated by Directive 2006/42/EC of the European Parliament and of the Council, as amended by the Czech technical regulation – Government Directive No. 176/2008 Coll., as amended, and the requirements of the harmonized Czech technical standards ČSN EN ISO 12100 and ČSN EN 13157+A1.

2.3 The product has been designed in compliance with the requirements stipulated by Directive 2014/34/EU of the European Parliament and of the Council, as amended by the Czech technical regulation – Government Directive No. 116/2016 Coll., as amended. The product has been designed as  **IM2c** equipment pursuant to ČSN EN 13463-1:2009 and ČSN EN 13463-5:2012. It complies with the conditions stipulated for use in mining environments classed as “hazardous atmospheric conditions 2” pursuant to ČSN EN 1127-2.

2.4 The product has been designed in compliance with the requirements stipulated by Directive 2014/34/EU of the European Parliament and of the Council, as amended by the Czech technical regulation – Government Directive No. 116/2016 Coll., as amended. The product has been designed as  **I12GDcT85°C** equipment pursuant to ČSN EN 13463-1:2009 and ČSN EN 13463-5:2012. It complies with the conditions stipulated for use in environments classed as „zone 1 and zone 21“, “zone 2 and zone 22“, pursuant to ČSN EN 1127-1.

Note: 2.3 and 2.4 articles apply for a winch designed for use in an environment with explosion hazard.

! WARNING

Winches for operation in environments with potential risk of explosion must not be fitted with a standard cable with an aluminium alloy sleeve. Only cables with a steel sleeve or splice may be used.

3 SECURITY PRINCIPLES

3.1 SECURITY PRINCIPLES OVERVIEW

A hazard of an accident and serious injury exists when handling loads especially in the event that the winch is used in a wrong way or is badly maintained. Therefore it is necessary to observe special security measures when handling, assembling, maintaining and checking the winch.

! WARNING

- NEVER** use the winch for lifting and transport of persons.
- NEVER** lift or transport loads above people or close to them.
- NEVER** burden the winch more than is the load capacity indicated on the winch, see table in the article 7.1.
- ALWAYS** make sure that a load bearing structure safely holds the fully loaded winch and all lifting operations.
- ALWAYS** warn persons in neighborhood before starting work.
- ALWAYS** read the operation manual and security instructions.

Bear in mind that the operation staff is responsible for faultless technique of tying, lifting and pulling of loads. Hence verify all national directives, regulations and standards whether they contain other information on safety work with your winch.

3.2 SECURITY PRINCIPLES

! WARNING

3.2.1 Prior to use

- ALWAYS** ensure the winch would be operated by physically fit, qualified and instructed persons older than 18 years, familiarized with the Operation Manual and trained in security of work and method of operation.
- ALWAYS** check up the winch every day before starting work according to the section 8.2. (1) „Daily inspection“.
- ALWAYS** make sure that the rope length is adequate for intended work.
- ALWAYS** use only an original rope.
- ALWAYS** ensure the rope is unruined, undistorted, clean and undamaged.

- NEVER** handle loads fixed fast or of unknown weight.
- NEVER** tension the rope without knowledge of necessary stretching forces.
- NEVER** use the defective or outworn winch.
- NEVER** use ropes with jumped out, damaged or missing trigger of the hook.
- NEVER** use the winch without visible load capacity marking on the winch.
- NEVER** use modified or deformed hooks.
- NEVER** connect or lengthen the rope by means of clamps or another way.
- NEVER** use the winch marked with the label „**OUT OF OPERATION**“.
- ALWAYS** consult the producer or his authorized representative about any application of the winch in nonstandard or extreme environment.

3.2.2 When in use

- ALWAYS** remove a deflection and rope loops before starting to lift or pull.
- ALWAYS** make sure the load is properly hitched over the hook.
- ALWAYS** make sure the hook trigger is properly snapped.
- ALWAYS** pay attention to excessive lifting or lowering (the end position – to unreel the rope only to a red sign on the rope).
- ALWAYS** work with the winch only with man power. Do not lengthen the crank.
- NEVER** use the jack for stretching or anchoring of loads.
- NEVER** allow the load sways or gives rise to impacts or vibrations.
- NEVER** use the rope of the winch as a tying instrument.
- NEVER** hang a load on the hook point.
- NEVER** pull the rope over any edge. Use the pulley.
- NEVER** weld, cut or carry out other operations on the hitched load.
- NEVER** use the rope to ground connection when welding.
- NEVER** work with the winch if the rope is hacked or hitched.
- NEVER** handle the rope without gloves.
- NEVER** touch movable parts of the winch while in operation. Ensure any subjects or other their parts do not get into the tothing.

3.2.3 After use

- NEVER** leave a hitched load without control or reliably secured.

3.2.4 Risk analysis

The possible risks analysis in light of design, operation and environment of the winch appointment is presented in freestanding document „Risk analysis“. It is possible to require the document in service centers.

3.2.5 Maintenance

- ALWAYS** make possible to competent persons to carry out any regular inspection of the winch.
- ALWAYS** ensure the rope is clean and undamaged.
- ALWAYS** ensure the tothing is sufficiently greased.
- ALWAYS** consult the producer or his authorized representative about the application of the winch in nonstandard or extreme environment.
At maintenance only such interventions can be done, that will be in accordance with producer's requirements stated in the chapters 11 and 14 of this Operation Manual.

IT IS NOT PERMITTED to carry out repairs and maintenance in other manner than specified by the producer. It concerns namely the forbiddance of using of unoriginal spare parts or carrying out modifications on the product without the approval of the producer.

4 ACCESSORIES, PACKING, STORAGE AND HANDLING

4.1 ACCESSORIES

The accessories of any winch are as follows:

- (1) Hand crank
- (2) Spring pin

4.2 PACKING

4.2.1 Winches are supplied with a dismantled crank and spring pin in a PE bag, packed in cardboard boxes. Winches are supplied already from the producer with wound on ropes on drums.

4.2.2 The following accompanying documentation is a part of the delivery:

- a) Operation Manual
- b) EC Declaration of Conformity
- c) Quality and Completeness Certificates and Guarantee Certificate.
 - C1) Guarantee period is stated in the Guarantee Certificate.
 - C2) The guarantee does not apply to defects caused by infringement of the instructions stated in the Operation Manual and defects occurred by an improper application and unqualified action.
 - C3) The guarantee does not apply as well to modifications on the product or using of unoriginal spare parts without the approval of the producer.
 - C4) A claim for defects in the product must be applied according to the relevant provisions of the Commercial Code or the Civil Code, as amended.
- d) List of service centers (only for the Czech and Slovak Republics)

4.3 STORAGE

Store winches and ropes in dry and clean stores void of chemical impacts and noxious fumes. When storing a separate rope, ensure each rope is easy to identify and compare with inspections records.

- (1) Store always the winch without any load.
- (2) Wipe away all dust, water and impurities from the winch.
- (3) Grease the rope, tothing and spring of the hook trigger – see the article 10.3.
- (4) Store the winch in a dry place.
- (5) In next use follow instructions in the article 8.1.2 „Daily inspection“ and 8.1.4 „Winch occasionally used“.

4.4 HANDLING

During transportation and handling, observe technical regulations and standards in force for work with heavy loads.

5 MAIN SPECIFICATIONS

tab 5a. SPECIFICATIONS

Type	Load capacity (t)	Rope (mm)	Height of lift (m)	Gear ratio	Range of operating temperature	Actuating force on crank max. (N)	Weight of winch with rope (kg)
LN / 0,5t	0,5	∅5	10	1:8	-20°C to +50°C	250	9,5
LN / 1t	1	∅8		1:6		250	15,2

tab 5b. MAIN DIMENSIONS

Type	Main dimensions (mm)									
	A	B	C	D	E	F*	G*	G1	L	R
LN/0,5t	264	167	344	193	186	144	115	19	5	200
LN/1t	373	207	460	240	209	160	160	19	8	300

*) hole distances for anchoring of the rope winch

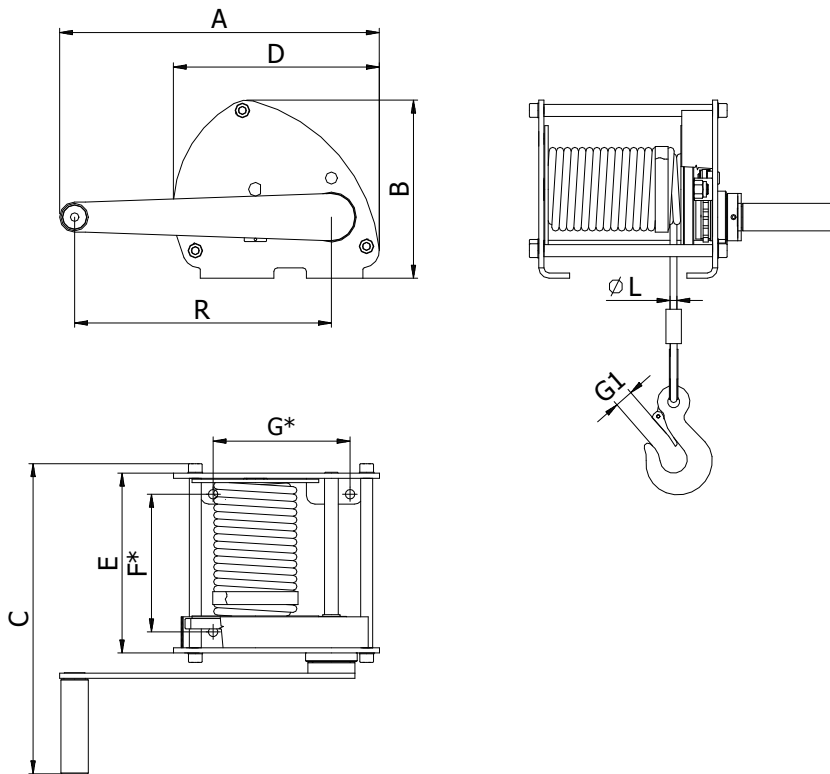

5.1 MECHANICAL CLASSIFICATION

Safety and operation life of the winch is guaranteed provided that it works in accordance with prescribed classification.

The winch is designed for the 1Bm class according to the FEM 9.511 regulation – see tab. 5.1 (it complies with the mechanism classification M3 according to the ISO 4301/1 standard).

The load diagram specifies the average daily working time.

Tab. 5.1 MECHANICAL CLASSIFICATION

Load diagram (load distribution)	Definition	Load coefficient	Average daily working time (h)
1 (light)	Winches usually being subject to the low load and only in special cases to the maximum load.	$k \leq 0,50$	1 – 2
2 (mean)	Winches usually being subject to the low load, but quite often to the maximum load	$0,50 < k \leq 0,63$	0,5 – 1
3 (heavy)	Winches usually being subject to the mean load, but frequently to the maximum load.	$0,63 < k \leq 0,80$	0,25 – 0,5
4 (very heavy)	Winches usually being subject to the maximum load or load approximating to the maximum.	$0,80 < k \leq 1,00$	0,12 – 0,25

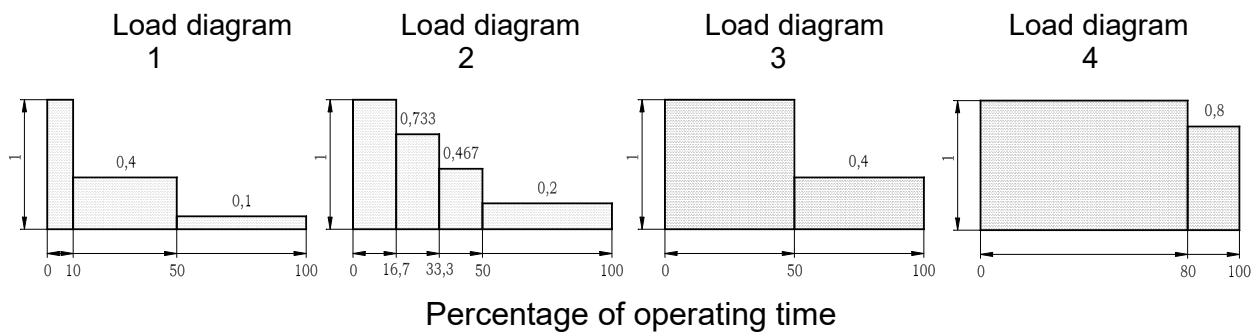

5.2 MATERIAL AND FINISH

5.2.1 Main parts of the winch are manufactured from steel and cast iron, the brake liners from brass. The crank handle surface is from PVC.

5.2.2 A finish protection of the winch is performed by galvanized zinc coating.

5.2.3 Materials susceptible to a creation of an incentive spar within the meaning of the Annex No.2 Article 1.3.1 to the ministerial order No. 116/2016 of the Collection of Law and the ČSN EN 1127-2 article 6.4.4 and ČSN EN 13463-1 article 8.1 harmonized technical standards are not used in the winch design.

5.2.4 Materials with dangerous effects of static electricity within the meaning of the ČSN EN 1127-2 article 6.4.7, ČSN EN 1127-1 article 6.4.7, ČSN EN 13463-1 article 7.4.3 and ČSN 33 2030 are not used in the winch.

5.2.5 The product does not exceed the noise value specified in the Annex No.1 article 1.7.4.2 letter u of the ministerial order No. 176/2008 of the Collection of Law (EP and RE directive No. 2006/42/EC).

Note: Articles 5.2.3 and 5.2.4 apply for winch finish to environment with explosion risk.

5.3 DATA ON THE PRODUCT

Each winch is equipped with the label with specified data as follows:

Standard finish:	Finish to environment with explosion risk:
Mark of the producer	Mark of the producer
Address of the producer	Address of the producer
Product type	Product type
Load capacity	Load capacity
Serial number	Serial number
Production year	Production year
CE marking	CE marking
	Protection type symbol (<i>IM2c</i> for group I, <i>II2GDcT85°C</i> for group II)

6 WINCH INSTALLATION

After unpacking of the winch at first attach the hand crank. Put on the crank to the end of the drum hub (1) so that holes on the hub and crank mutually overlap. Then beat into the hole the enclosed spring pin (2) – see figure.

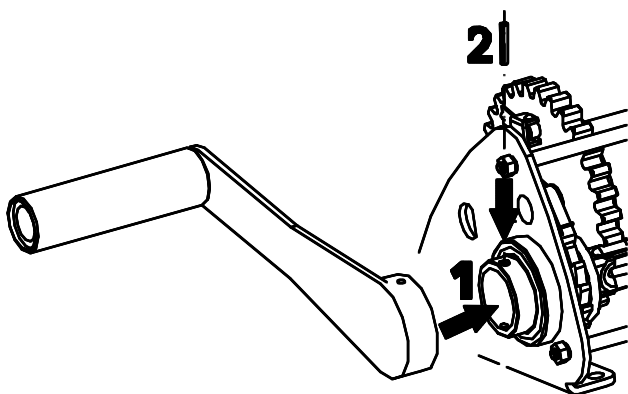

6.1 CHECK BEFORE INSTALLATION

6.1.1 Load bearing structure

! WARNING

ALWAYS make sure that the load bearing structure is sufficiently firm to hold the load and winch. The installation must not be carried out on the structure, when the load capacity cannot be verified.

ALWAYS the user is responsible for the load bearing structure!

6.1.2 Check of rope

Check whether the rope is clean, undistorted and undamaged.

6.2 WINCH ATTACHMENT

! NOTICE

When attaching the winch to the load bearing structure respect utmost precaution and ensure proper conditions for safety installation pursuant to a character of the environment (working platform, auxiliary hoist etc.), so that jeopardy or injury of persons do not take place. When attaching the winch aloft use protective means against falls from the height.

For the rope winch attachment use undamaged screws, pads and nuts.

ALWAYS safeguard the winch attachment with all four screws.

ALWAYS safeguard the winch attachment so that the pulled load moves in winch axis.

The user is responsible for creation of conditions for the winch installation!

6.3 WINCH POSITION WHEN PULLING AND LIFTING

(1) The rope must be reeled up perpendicular to the winch drum.

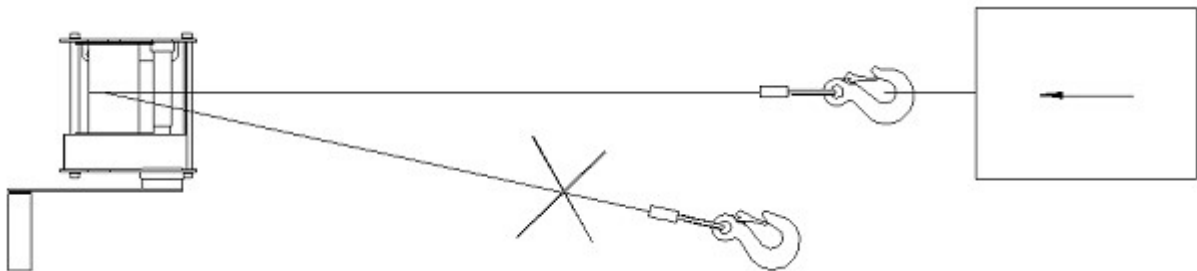

(2) If the winch and load are not in-line when lifting or pulling a balancing pulley must be used for a rope guide. Minimum diameters of pulleys are specified in the tab.6.3.

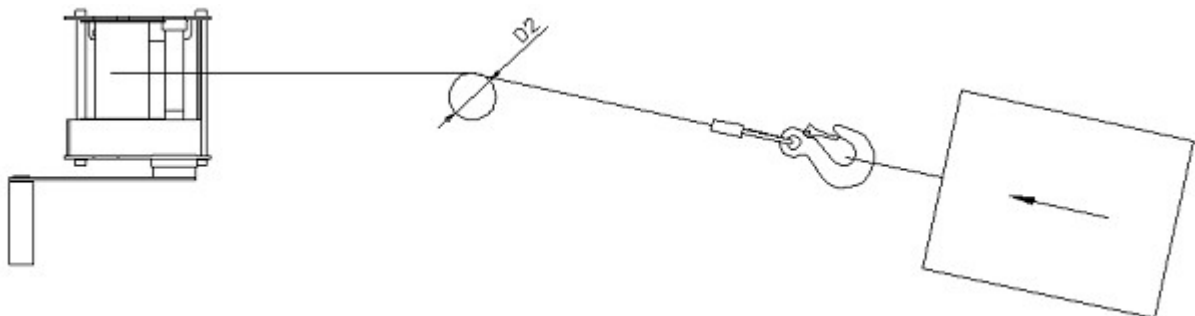

(3) Possible positions of the rope when operating the winch are specified in the figure.

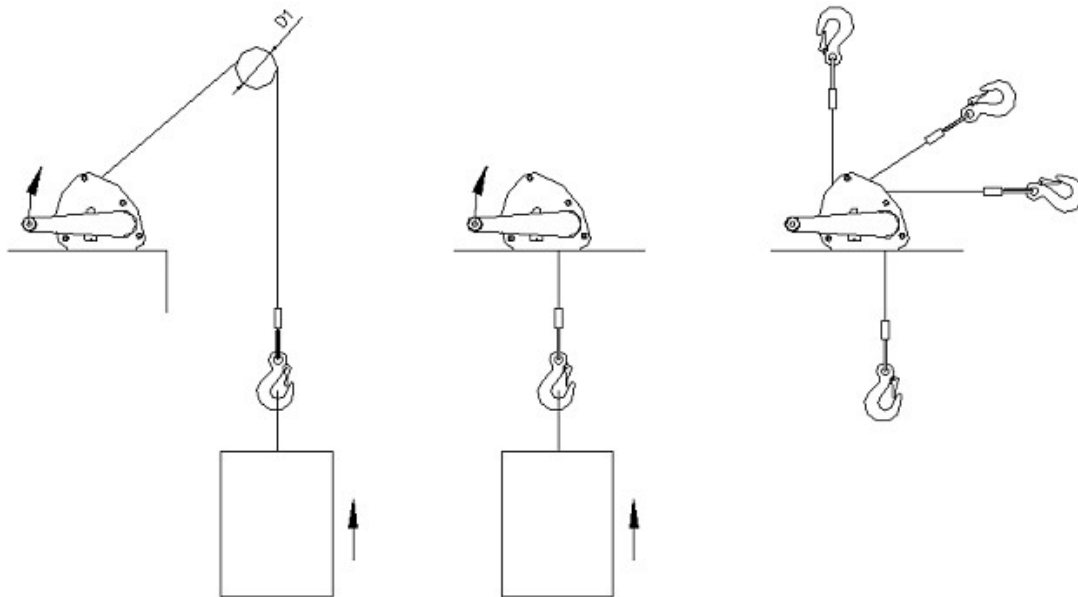

Tab.6.3

Load capacity (t)	Rope diameter (mm)	Minimum diameter* (mm)	
		of pulley D ₁	of balancing pulley D ₂
0,5	Ø5	60	
1	Ø8	96	

*) wheel pitch diameter

6.4 INSTRUCTIONS FOR WINCH OPERATING STAFF

The lifting and lowering of a load can be interrupted in any height of the lift. A self-acting brake of the winch safeguards position stability.

6.4.1 Stretching and slacking of rope

By a rotation of the crank we stretch the rope and draw near the load. By change in direction of the crank rotation we then lower the load and slack off the rope.

! NOTICE

ALWAYS when reeling up the rope without any working load, use an auxiliary load of the weight c. 5kg or adequate power c. 50 N for safeguarding needful initial loading of the rope. Thereby you will ensure a proper placing of the rope on the drum which is a condition for the failure-free operation.

! WARNING

NEVER lift or lower the hook to end positions. When lowering always leave 3 coils of the rope at minimum on the drum. The minimum rope length which must stay reeled up on the drum is marked with a red strip on the rope.

6.5 TEST PRIOR TO USE

! NOTICE

At first read again the previous articles of this manual and make sure that all steps were correctly done and all parts are safety mounted.

- (1) Check whether the rope is not distorted.
- (2) Check the attachment of the hook with the rope and if the hook trigger is snapped.
- (3) Visually check the load bearing structure or suspension elements if they are not damaged.
- (4) By several rotation of the hand crank, test the function of the winch without working load.
- (5) Carry out several lifting and lowering with a suitable load (10% to 50% of the load capacity). At the same time, verify, whether the winch holds firmly the load without brake slipping when lowering and stopping.

7 OPERATION

7.1 WINCH APPLICATION

The winch is multifunctional equipment destined for relocating and lifting of loads. It is operated by means of the hand crank. It is destined for both organizations and private persons. It can be used not only in normal environment, but also in environments of explosion risk, if the label contains a sign of the protection type – see articles 2.3 and 2.4 of this OM.

For the work with heavy loads can constitute an unexpected hazard, it is necessary to follow all „Security principles“ according to the chapter 3 of this manual.

The weight of towed loads depending on the gradient of the terrain and the type of friction (sliding – rolling) is given in pic.

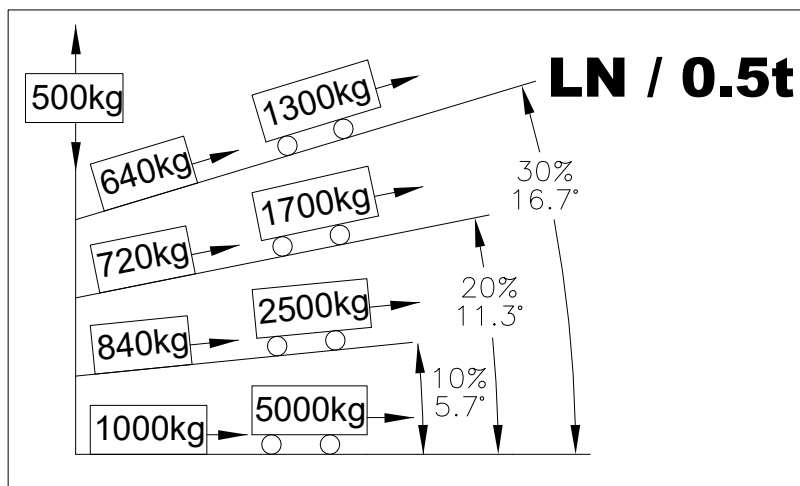

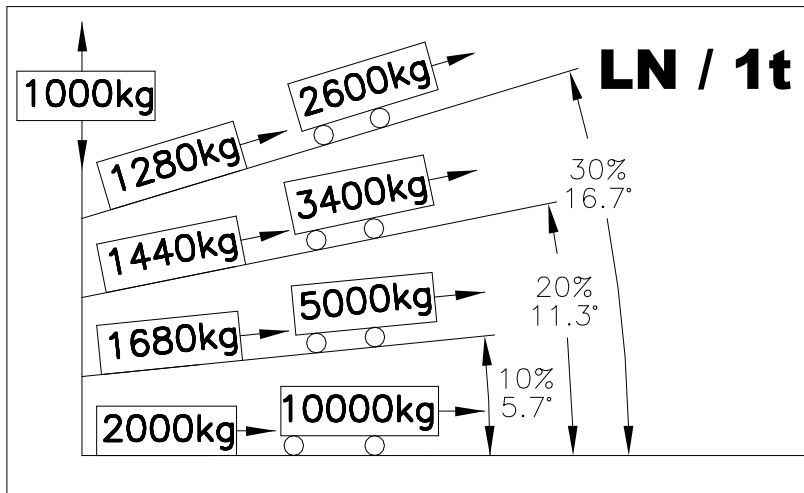

The weight of loads according to the tables is only approximate and applies for level and solid surfaces

! WARNING

NEVER handle a load by a diagonal pull of the rope (see 6.3.1). Slipping of the rope from the drum could happen.

7.2 LIFTING AND LOWERING

The lifting and lowering of loads is performed by the rotation of the crank in the appropriate sense. The lifting and lowering can be interrupted at any lift height.

! WARNING

At winches provided by longer rope (above 15m) hazardous heating of brake can happen when lowering a load in extraordinary cases (uninterrupted and rapid lowering). In such cases it is necessary to lower loads slowly and step-wise.

! WARNING

Never hook up a load to the winch without previous active jacking up of the load by a jack. The load can fall down from the reason of the released brake.

The winch brake is reliably activated at minimum loading from 2% up to 5% of the safe working load.

! NOTICE

When lifting loads being in the lifted state hooked over on other hosting device (crane, lift truck etc.) it is necessary to release the rope by the hand crank of the winch not by lifting of the load with the other hoisting device. Only the specified procedure guarantees trouble free releasing of the brake of the winch after taking off the load.

7.3 SAFETY WORK ENVIRONMENT

! WARNING

- (1) The operating personnel of the winch must be demonstrably acquainted with this Operation Manual, must comply with the valid security and hygienic regulations and must be entitled to the operation of this equipment.
- (2) At work with the winch the operating staff must be equipped with a protective helmet, gloves and appropriate footwear.
- (3) For tying of loads only verified tie means of appropriate load capacity must be used.
- (4) When operating by more persons always one employee trained in occupational safety and health must be determined as the responsible person for handling with the winch.
- (5) The operating personnel of the winch must have a free and enshrouded by anything view of the whole working area still before starting the work. If it is not possible, one or more persons close to the winch must help to supervise.
- (6) Before work initiation the operating personnel must check up, whether the whole working area is safety and whether there is a possibility of eventual escape from the environment of jeopardy.
- (7) When operating the winch the sufficient distance between the operating staff and a load must be observed. It is forbidden to lift or lower voluminous loads which disable to observe a sufficient distance.
- (8) If you work with the winch in a limited area you have to ensure the hook or load does not crash into any obstacle or winch's body.
- (9) When winding on the drum the rope must be close-coiled and must not be crosswise.

8 WINCH INSPECTION

8.1 INSPECTION

8.1.1 Inspections types

- (1) Introductory inspection: it precedes first use. The responsible competent person determined by the user must inspect all new or repaired winches to ensure the qualified fulfillment of requirements of this OM.
- (2) The winch inspections carried out regularly are generally divided into two groups according to inspections intervals. Intervals depend on the state of critical parts of the winch and its rate of wear, damage or malfunction. Two main groups are here marked as daily and regular ones. The appropriate intervals are defined as follows:

(a) Daily inspection: visual inspection carried out by the operation staff determined by the user that is made at the beginning of each use.

(b) Regular inspection: visual inspection carried out by the competent person determined by the user.

- 1) Current operation – once a year,
- 2) Heavy operation – every six month,
- 3) Special or occasional operation – according to recommendations of the competent person at first use and according to the order of qualified employees (maintenance workers).

8.1.2 Daily inspection

Check up at parts recommended in the section 8.2(1) „Daily inspection“, whether the winches are neither damaged nor have any defect. Carry out this inspection also during operation in the interval between regular inspections. Qualified employees will determine whether any defect or damage can constitute a hazard and whether the detailed inspection is necessary.

8.1.3 Regular inspection

Carry out overall inspections of the winch in a form of recommended regular inspections. At such inspections the winch can stay on its usual place and it need not be taken to parts. The recommended regular inspection stated in the section 8.2(2) must be performed under supervision of competent persons that will determine, whether the winch is necessary to be taken to parts. These inspections comprise also requirements of the daily inspection.

8.1.4 Winch occasionally used

- (1) Submit the winch not being in operation for a period of one month or longer but less than a year to inspection complying with requirements in section 8.1.2 before follow-up putting it into operation.
- (2) Submit the winch not being in operation for a period of one year to inspection complying with requirements in the section 8.1.3 before follow-up putting it into operation.
- (3) The rope must be checked up according to requirements in section 8.1.3 always before recovery of winch operation, if it was out of operation for more than 3 months.



8.1.5 Report on inspection

Keep the record of performed tests, repairs, inspections and maintenance of winches every time. Carry out dating reports on inspections in intervals specified in the section 8.1.1 (2) (b) and keep them in the place specified by the user.

The person responsible for safety and determined by the user must be advised of defects detected by the inspection or recorded during the operation.

8.2 INSPECTION PROCEDURE

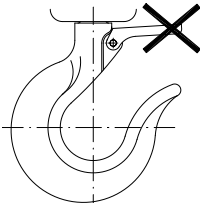
(1) Daily inspection (carried out by operating start or responsible person)

PART	INSPECTION METHOD	LIMIT/CRITERION for putting out of operation	REMEDY
1. Winch function	Visually, aurally	The winch goes hardly, stammers, emits noise etc.	To clean up and grease the winch, to check up the rope. If the defect will not be removed, get the jack repaired.
2. Fixative parts	Visual inspection of all screws, nuts, rivets etc.	Faulty or missing parts; Released parts	To replace by new ones; to retighten released parts
3. Hooks (1) Appearance	Visually 	Jumped out trigger from hook point, crooked hook shank or other visible hook deformations	Stretched hook – replacement of hook with rope
(2) Hook trigger	By manual spring-back of trigger	Trigger do not return after pressing	To clean up and grease, repair or replacement
4. Rope Appearance	Visually check up whole rope 	Dust, impurity, deformation, abnormal wear, corrosion Damaged or deformed rope, abnormal wear, corrosion	To clean up with brush, grease and wipe surface with swab Replacement of rope with hook
(1) Greasing	Visually	Rope is not greased	To clean up and grease rope, wipe surface with swab
(2) Rope adjustment	Visual inspection if rope is not distorted	Rope is distorted or crooked	Straighten rope and adjust it to normal position

(2) Regular inspection (carried out by competent person)

PART	INSPECTION METHOD	LIMIT/CRITERION for putting out of operation	REMEDY
1. Fixative parts	Visual inspection of all screws, nuts, rivets etc.	Faulty or missing parts; Released parts	Replace by new ones; To retighten released parts

2. All parts	Visual inspection	Outworn or damaged parts; Fouled and ungreased parts	Replace by new ones; To take to parts, clean up, grease and reassemble
3. Label – marking of load capacity on the jack	Visual inspection	Load capacity is not readable	To repair or replace by new one
4. Hooks (1) Hook deformation (opening) See tab. 8.2.1 (2) Hook wear	Measure size „g“ with caliper Visual inspection Measure size „e“, „h“ and „d ₂ “ with caliper	Measured value is greater than stated in tab.8.5 Deformation is visible at visual inspection If size „e“, „h“ or „d ₂ “ decreases for more than stated in tab. 8.5	Replacement of hook with rope Replacement of hook with rope Replacement of hook with rope
5. Rope attachment	Inspection of tightening of screws	End of rope is not sufficiently attached to drum	To tighten fixative screws
6. Pawl - function	Visual inspection when lifting	Pawl do not snap behind dents of ratchet	To clean up and grease or change spring
7. Rope - criteria for putting it out of operation	(1) Number of visible broken wires – see table 8.2.2 Carry out inspection of whole rope length. Put rope out of operation, when several broken wires concur close to each other, so that they create a group in given place or if whole rope strand pulls apart. (2) Rope diameter reducing – maximum by 10%. (3) Outside wear - rope diameter reducing owing to galling, by surface wear, inside wear etc., it can be maximum by 7% from nominal diameter of rope. (4) Rope corrosion (outside and inside). (5) Rope deformation – visible change of rope shape against its normal shape. (6) Defect caused by fire or electric arc. At all inspections individual factors must be considered when keeping under review particular criteria.	Replacement of rope with hook Replacement of rope with hook Replacement of rope with hook Replacement of rope with hook Replacement of rope with hook Replacement of rope with hook	

8.2.1 Table for evaluation of rope deformation

Hook with eye								
Hook type	Size "e" (mm)		Size "h" (mm)		Size "g" (mm)		Size "d ₂ " (mm)	
	nom.	max.	nom.	min.	nom.	max.	nom.	min.
HS 5-6	80	84	20	18	25	27,5	8,5	7,65

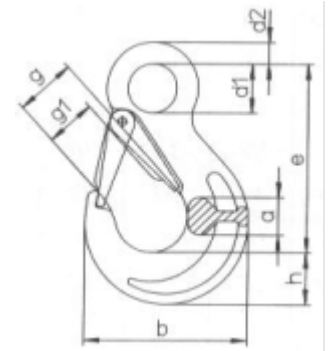

8.2.2 Table for evaluation of rope damage

Rope diameter (mm)	Controlled length (mm)	Max. number of broken wires
Ø 5	1. 30	5
	2. 150	10
Ø 8	1. 48	5
	2. 240	10

1. Check on the length stated in the line 1; if maximum is gained we continue to check as to line 2.

9 TROUBLE-SHOOTING

Situation	Cause of trouble	Remedy
1. Winch lifts heavily or does not lift the load	(1) Winch is overloaded. (2) Damaged tooth gear.	(1) Decrease weight of load up to safe working load. (2) Check up components according to chap. „Maintenance“
2. Hand crank spins free.	Pin destruction. Destruction of weld joint drum-toothed wheel (0,5t), pinion-shaft (1t)	Pin replacement. Drum replacement. Pinion shaft replacement.
3. Characteristic sound is not heard when snapping pawl to dents of ratchet.	(1) Loss of pawl function. (2) Corrosion, impurities, blow out spring.	(1) Pawl spring replacement. (2) Cleanup, spring replacement.
4. Hook trigger does not snap.	(1) Damaged trigger. (2) Deformed hook.	(1) Repair trigger. (2) Check up hook – see „Daily inspection“.
5. Hand crank heavily rotates when unreeling.	Brake liners are outworn, choked by impurity.	Cleanup, check of liners thickness– according to state - replacement. Put up repair to skilled workshop – according to service centers list

10 GREASING

10.1 GENERAL

Before application of new grease remove old grease from the toothed wheel gear, clean up components with grease solvent and apply new grease. Use grease specified by the producer. Clean the rope with a brush or by steam.

10.2 GEARS

Remove the old grease and replace with a new one. Use grease: Universal lithium plastic lubricant, water resistant, usable in a minimum range of working temperatures from -20°C to +50°C. For example A2, LV2EP.

10.3 ROPE

Faultive maintenance and insufficient greasing of the rope considerably decreases its operation life and can cause a serious accident. Lay on a film of oil on the rope and wipe off by a swab. Regular greasing precludes the wear and corrosion of the rope and extends its operation life.

! NOTICE

- ALWAYS** grease the rope once a week or more often according to operation exigency.
- ALWAYS** grease more often in a corrosive environment (salt water, oceanic climate, acids etc.) than under ordinary circumstances.
- ALWAYS** use table oil according to ISO – VG 46 or VG 48 or their equivalent.
- ALWAYS** after greasing wipe thoroughly the rope surface by a swab.
- NEVER** use cleansing liquid on an acid base.

11 MAINTENANCE

11.1 SECURITY PRINCIPLES

With the exception of a rope replacement, only qualified persons (service organizations), trained in safety and maintenance of these winches, can carry out the maintenance, professional inspections and tests.

- ALWAYS** use entirely components supplied by the producer.
It is not permitted to carry out repairs and maintenance other way than specified by the producer. It means namely the forbiddance of using unoriginal spare parts or carrying out of modifications on the product without the approval of the producer.
- ALWAYS** test winch function after carrying out maintenance by partial winding-off and winding-on of the rope.
- ALWAYS** mark disabled or repaired winch with the appropriate inscription (i.e. „**OUT OF OPERATION**“).
- NEVER** carry out maintenance if there is a load attached to the winch.
- NEVER** work with the winch being under repair!

11.2 ROPE REPLACEMENT

1) LN/0,5t

Unreel the rope from the drum, dismount the rope clamp and remove the old rope. The end of the rope run through a hole of the drum face and mount the rope clamp again to the rope.

We leave first thread groove free and start to reel up the rope from second thread groove.

2) LN/1t

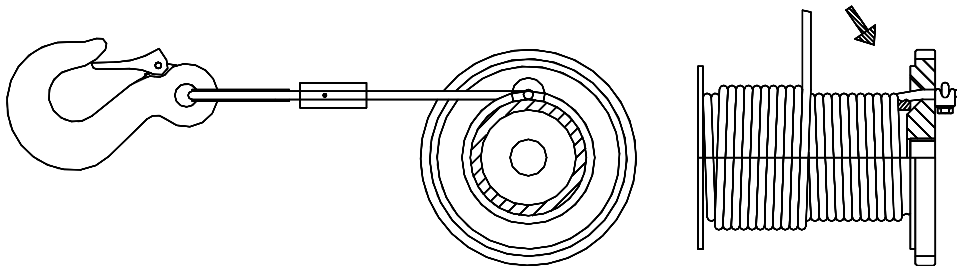

Unreel the old rope from the drum, loosen the nut of the rope screw (wrench access to the nut through a hole in a side plate) and remove the old rope.

An end of a new rope run through the hole of the rope screw placed in the hole of the drum face. By tightening of the nut the end of the rope is fixed. By rotation of the crank then reel the rope on the drum so that the rope is reeled from above the drum.

When reeling it is necessary to educe in the rope a counter extension c. 50 – 100 N by means of suitable load (weight). It is necessary to work with some helper that ensures continuous preload of the rope and correct guidance on the drum.

! WARNING

ALWAYS mount a new rope only in above mentioned manner. Other manner of the rope attachment on the drum can cause no functionality of the brake or pawls (!), eventually higher stress of elements of the winch attachment to the load bearing structure.

ALWAYS reel a new rope with necessary preload and be particular in correct laying it on the drum. The slack and cruciate rope has considerably lower life duration.

11.3 GENERAL INSTRUCTIONS

Following instructions give general important information on disassembly, check up, repair and assembly. If the winch was dismantled from any reason act upon the instructions as follows.

1. **ALWAYS** perform maintenance in clean environment.
2. **ALWAYS** keep the workplace clean and without foreign substances that can get into bearings and other movable parts.
3. **ALWAYS** use appropriate pads for protection of parts surfaces, if you intend to squeeze single parts in a vice.
4. **NEVER** disassemble the winch more than it is necessary to carrying out of needful repair.
5. **NEVER** use excessive power when dismantling parts.
6. **NEVER** use heat (fire) as the mean when dismantling parts, if the parts are destined for next use.

11.4 BRAKE ASSEMBLY AND ADJUSTING

Dismount the hand crank (2) from the carrier hub after expression of the spring pin (1) and dismount the back side plate (3) – after screwing out screws from distance rods.

We take off the back side plate from the winch. Then it is possible to take off from the face side plate the set of the toothed shaft with the brake (4).

We dismount the nut (6), take off the pad (7) and from the toothed shaft we screw off a carrier segment (8). Then we dismount by steps from the shaft the braking liner (9), ratchet (10), second braking liner (9) and support plate (11).

We perform the assembly of braking device by an opposite procedure.

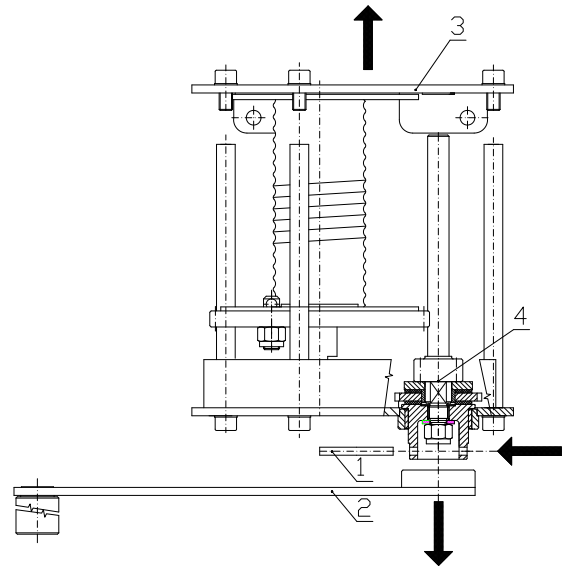

Brake adjusting:

After check up and assembly it is necessary to adjust the axial brake clearance.

We retighten slightly the carrier segment (8) so that between brake parts (9-11) the minimum clearance is set. Then we screw on the nut (6) and also slightly tighten. After assembling of the set of the toothed shaft with the brake between side plates and before put on of the hand crank we loosen the nut (6) by $\frac{1}{4}$ thread. Then we mount the hand crank and verify the brake function. Correctly adjusting brake has free travel approximately between $10^\circ - 15^\circ$. After adjusting it is necessary to test the winch at loading by testing load.

11.5 CHECK UP

ALWAYS check up all dismounted parts, whether they are suitable for next use.

1. Check up all toothed gearing including the shaft whether they are not worn-out or have no chutes or fissures.
2. Check up, whether threaded parts have no damaged thread.
3. Clean up the braking liners (9), ratchet (10), catch pawl and thrust washer (11) by a wire brush and check up their state.
4. Measure a thickness of the braking liners (see following table).
5. It is necessary to replace braking liners with thickness less than limiting one. Regardless of the thickness replace also the liners with surface considerably chaved.

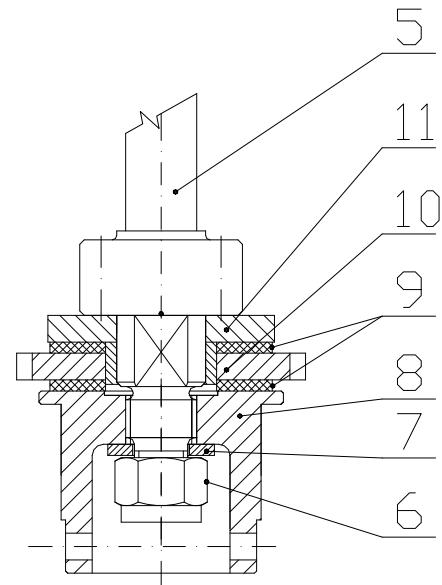

Liner thickness (mm)	Limit (mm)	Wear (mm)
2,5	2	0,5

6. Check up especially the rope inflicting troubles most often.

11.6 REPAIR

Worn-out or damaged parts must be replaced.

Remove little burrs and scratches or other minor surface defects and flatten out with fine grinder or abrasive cloth.

11.7 TEST

The load test must be performed at all repaired winches by qualified person with the load exceeding the load capacity by 10% for verification of function and brake of the winch.

12 PUTTING OUT OF OPERATION – DISPOSAL

All winch types do not contain any noxious agents. Their parts are from steel, braking liner from copper alloy and crank handle from PVC. Hand over the rope winch after putting it out of operation and dismounting the handle to the firm dealing with disposal of waste metal. (At disposal of the handle follow applicable standards for disposal of recyclable plastics).

13 RELATED DOCUMENTATION

of Law as amended

EC declaration of conformity

The Operation Manual was elaborated in accordance with following technical regulations, technical standards and national regulations:

- Ministerial order No.176/2008 of the Coll. of Law as amended (EP and Council directive 2006/42/EC)
- Ministerial order No.116/2016 of the Coll. of Law as amended (EP and Council directive 2014/34/EU)
- ČSN EN ISO 12100
- ČSN EN 13157+A1
- ČSN EN 1127 - 2
- ČSN EN 1127 - 1
- ČSN EN 13463 - 1
- Regulation of CBM (Czech Bureau of Mine) No.22/89 of the Collection of Law
- ČSN 33 2030.

14 FINAL REQUIREMENTS OF THE PRODUCER TO THE CUSTOMER

Any changes of the product, eventually usage of unoriginal spare parts can be realized only based on the approval of the producer.

When not observing this condition the producer does not guarantee safety of his product. In this case, any producer's guarantees do not apply to the product.

Quick expendable part, to which the guarantee does not apply, is:

- rope with hook

The guarantee of this part applies only on defects caused demonstrably by the defect of material.